

REVISION HISTORY				
ZONE	REV	DESCRIPTION	DATE	APPROVED

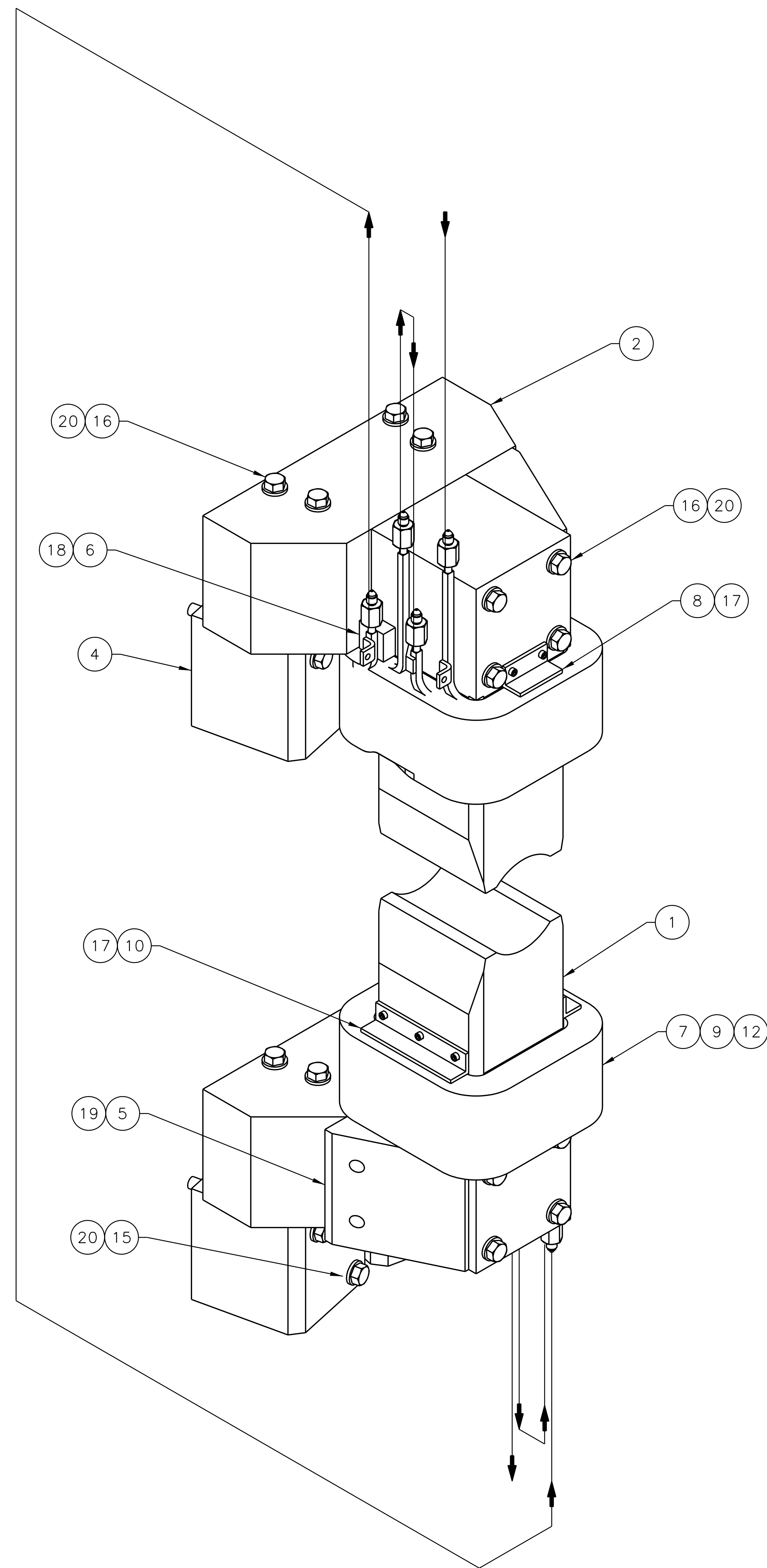

ISO VIEW 1-6C

NOTES:  
 1. APPROX. WEIGHT 305 LBS.  
 2. FIELD CLAMP CONNECTOR PLATES (ITEM 4) WILL BE MATCH MARKED TO Q1 MAGNET AT FINAL INSTALLATION IN HALL A.

QTY	ITEM NO.	PART OR IDENTIFYING NO.	DESCRIPTION OR IDENTIFYING NO.	MATERIAL	NOTES
24	20	McMASTER CARR 98029A045 OR EQ	WASHER OVERSIZED FOR 3/8 SCREW	BLACK OXIDE STEEL	-
4	19	FASTENAL 23209 OR EQ	SHCS 1/4-20 X 1.50 IN LG	STEEL	-
2	18	FASTENAL 23205 OR EQ	SHCS 1/4-20 X 1.00 IN LG	STEEL	-
16	17	FASTENAL 23803 OR EQ	SHCS #6-32 X .375 IN LG	BLACK OXIDE STEEL	-
16	16	FASTENAL 14123 OR EQ	HEX HD 3/8-16 X 5.00 IN LG	GR8 STEEL	-
8	15	FASTENAL 14120 OR EQ	HEX HD 3/8-16 X 4.50 IN LG	GR8 STEEL	-
-	14	-	-	-	-
-	13	-	-	-	-
2	12	A10009-04-01-0500	COIL BRAZEMENT DS	COMPOSITE	-
-	11	-	-	-	-
4	10	A10009-04-01-0003	BRACKET	ALUMINUM	-
2	9	A10009-04-01-0109	FRONT-BACK COIL SHIM	G-10	-
2	8	A10009-04-01-0108	BRACKET SHORT	ALUMINUM	-
2	7	A10009-04-01-0107	SIDE COIL SHIM	G-10	-
2	6	A10009-04-01-0106	COIL SUPPORT BLOCK	G-10	-
2	5	A10009-04-01-0105	IRON POLE DS SIDE SHIM	1018 STEEL	-
4	4	A10009-04-01-0104	FIELD CLAMP CONNECTOR PL	1018 STEEL	2
-	3	-	-	-	-
2	2	A10009-04-01-0102	IRON YOKE DS	1018 STEEL	-
2	1	A10009-04-01-0101	IRON POLE DS TOP	1018 STEEL	-

DOCUMENT CONTROL STAMP		TRACKING NO.		United States Department of Energy	
MATERIAL: SEE PARTS LIST		N/A		Jefferson Lab Thomas Jefferson National Accelerator Facility Newport News, Virginia	
FINISH: MACHINED SURFACES DEBURR & BREAK ALL SHARP EDGES		THIRD ANGLE PROJECTION		HALL A - EXP E10009 APEX MAGNET - DIPOLE BEAM TO DUMP SEPTA MOUNT APEX DIPOLE BEAM TO DUMP CORRECTOR DS	
UNLESS OTHERWISE NOTED		APPROVALS: J. MILLER		DATE: 17MAY16	
DO NOT SCALE DRAWING		APPROVED: [Signature]		SCALE: 1:2	
		APPROVED: [Signature]		SHEET 1 OF 2	

IN ACCORDANCE WITH THE JEFFERSON LAB ESH&Q MANUAL SUBJECT MATTER EXPERT (SME) SIGNATURES MAY BE REQUIRED.

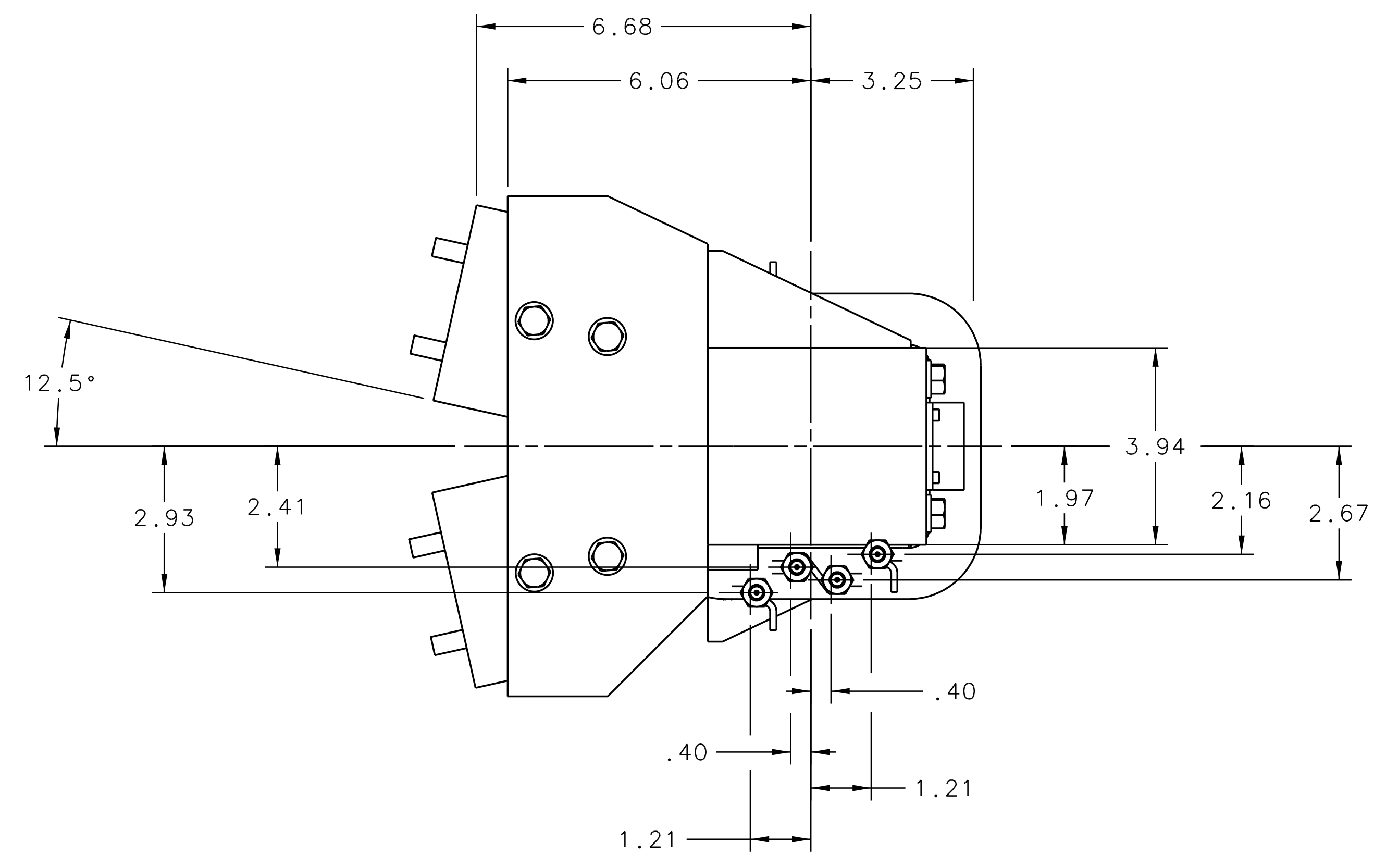

TOP VIEW 2-7F

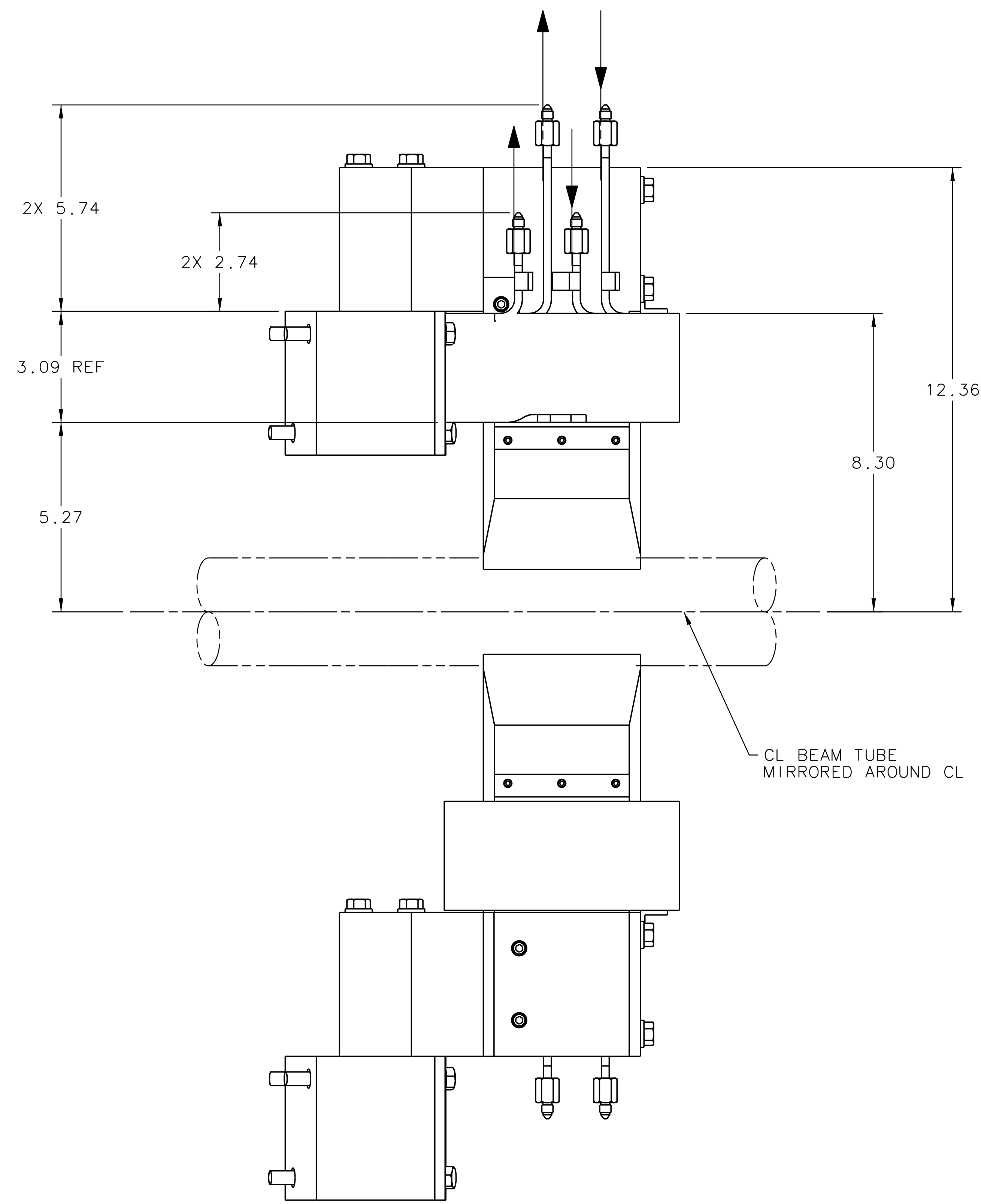

FRONT VIEW 2-7A

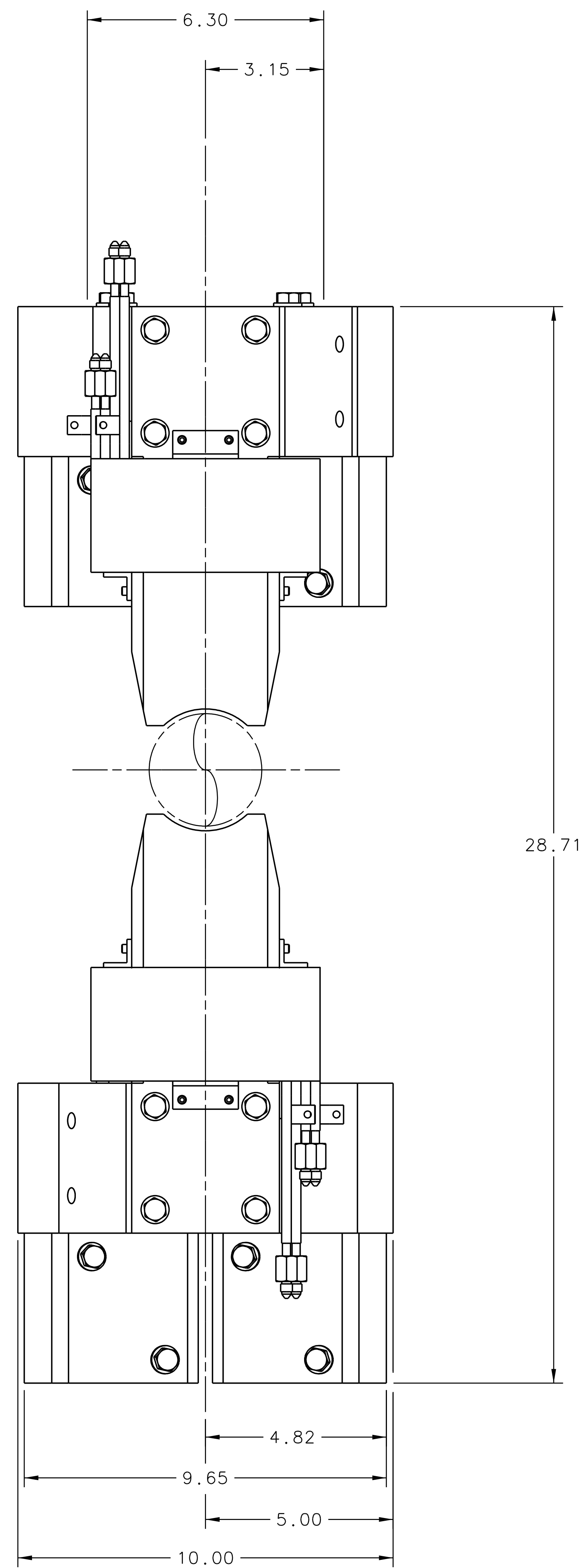

SIDE VIEW 2-4A

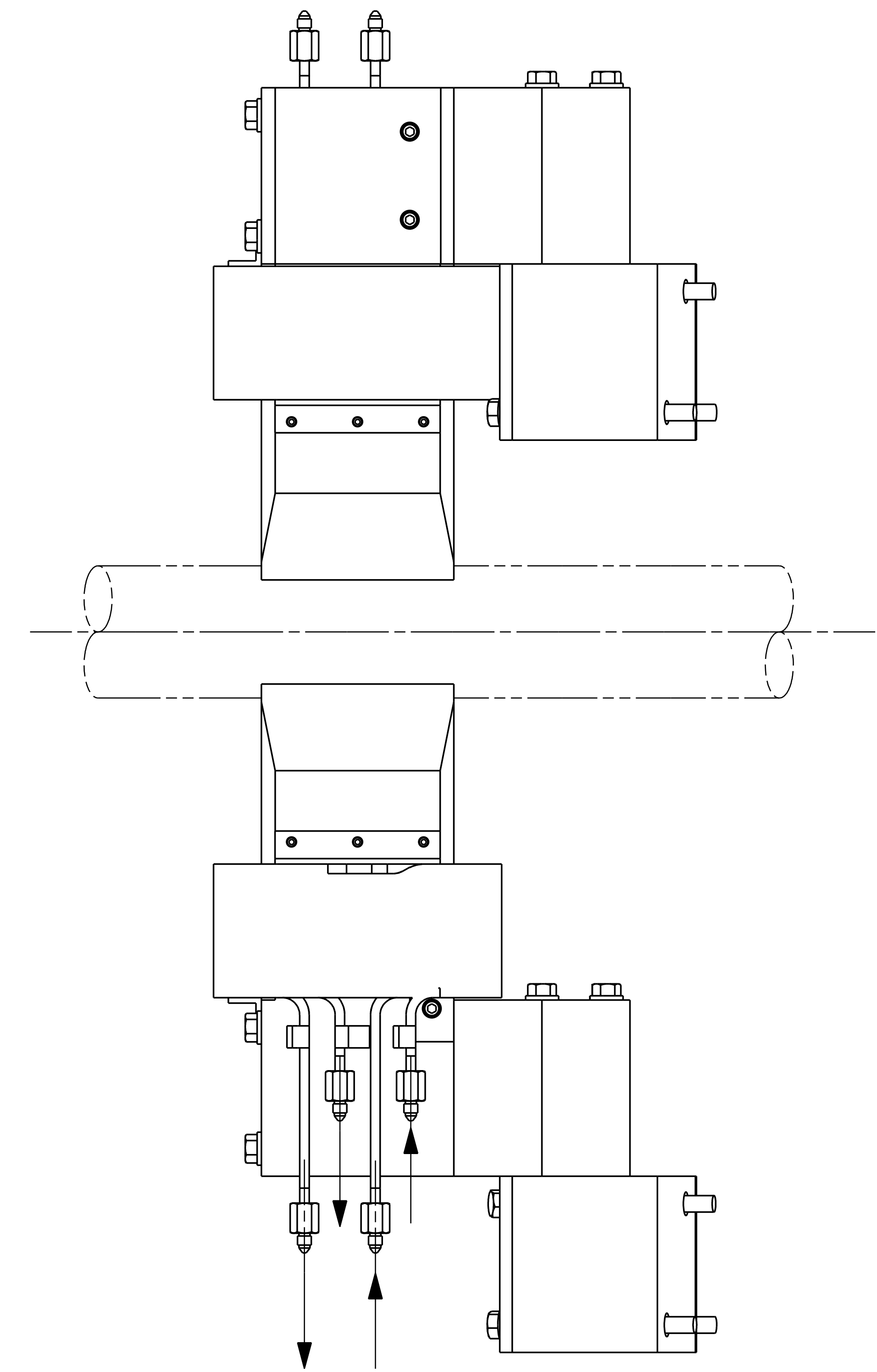

BACK VIEW 2-2A

DOCUMENT CONTROL STAMP	SIZE DWG. NO.	REV.
<b>E</b>	A10009-04-01-0100	-
SCALE	ISSD OR ASSY NO.	SHEET
1:2	N/A	2 OF 2